

This valve provides a momentary (pulse) output at its cylinder port when pressure is applied at its inlet. No additional flow is possible until pressure at the inlet is removed, reset time allowed, and pressure reapplied. Reset time is slightly longer than output pulse time.



OS-1

Operation

When the incoming signal is applied to the **IN** port, the spool is immediately shifted, allowing the pressure to and through the **CYL** port, becoming the output signal.

Pressure then bleeds across an orifice through the piston head. When pressure is equal on both sides of the piston head there is a force unbalance on the spool. This force unbalance returns the spool to its original position. In this position the incoming signal is blocked and the **CYL** is connected to the **EXH**, in turn venting the output signal.

Before the valve can produce another output signal it must be reset. This is accomplished when the input signal is removed from the **IN** port and the pressure behind the piston bleeds back through the orifice and drops to zero psi. This also self cleans the orifice every cycle. The next incoming signal can then produce another output signal.

NOTE! The incoming signal **MUST** be of sufficient pressure and volume to shift the spool before bleeding across the orifice and balancing out.

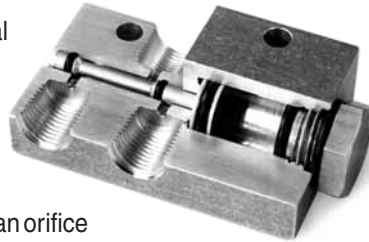

Features

- One moving part.
- Buna-N seals.
- Pulse time preset at factory. (See Model Chart)
- Shorter pulse can be field set with ordinary sewing needle.
- Can be cleaned or repaired without removing from installation.
- Spool action can be observed for trouble shooting circuit.
- Operating pressure: 45 to 150 psi.
- Operating temperature: 0° to + 180°F.
- No springs.
- Self-cleaning orifice.

Applications

- **Signal Conversion - Pulse**, to convert a constant or maintained signal from a limit valve or other source to a pulse or momentary signal for a double piloted valve or other device. This allows the double piloted valve to be shifted back even though the originating limit valve is still held open. See sequencing circuit on page 13.4.
- **Single Cycle**, to convert a signal from a hand or foot control to a pulse signal. This allows only one cycle of the circuit even if the operator holds the starting device on. The operator must release the starting device to reset the one-shot / pulse valve and then reactuate to achieve the next cycle. See pressure sensing circuit on page 13.4.
- **Open End Blast**, to provide a pulse of air through a nozzle or tube for automatic part blow off or chip removal.

Sizing

Model Number	Approximate Pulse Time, Seconds @80 psi	Approximate Reset Time, Seconds @80 psi	Port Size	Weight Oz.
OS-1	3/4	1	1/8 NPT	3.1
OS-3	1-1/2	2	1/8 NPT	4.8

Symbol

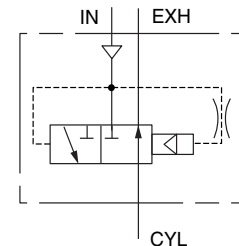

Dimensions

Model No. OS-1 & OS-3 1/8 NPT Ports

Materials:

Body, Aluminum, Unanodized
Cap, Brass
Spool, Aluminum

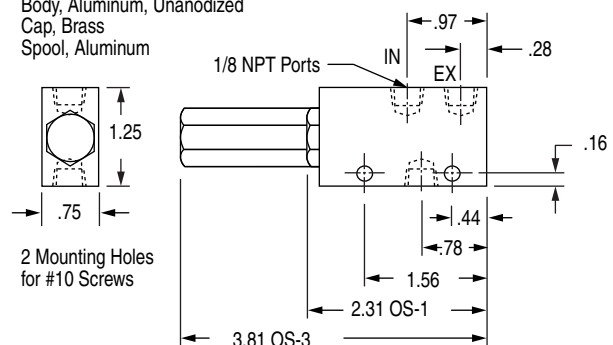



Sizing

Model Number	RV-1	RV-2
Port Size, NPT	1/8	1/4
Weight	4.7 oz.	4.6 oz.

Features

- Simple - One moving part
- Corrosion resistant construction
- Black anodized aluminium body
- Light weight
- Compact
- Repairable
- Buna-N seals
- Simple adjustment
- Operating temperature 0° to + 180°F

Operating pressure: 20 to 150 psi

Standard Spring: 50 to 150 psi

Light Spring: 20 to 55 psi

Light spring and instructions included with each unit.

Dimensions

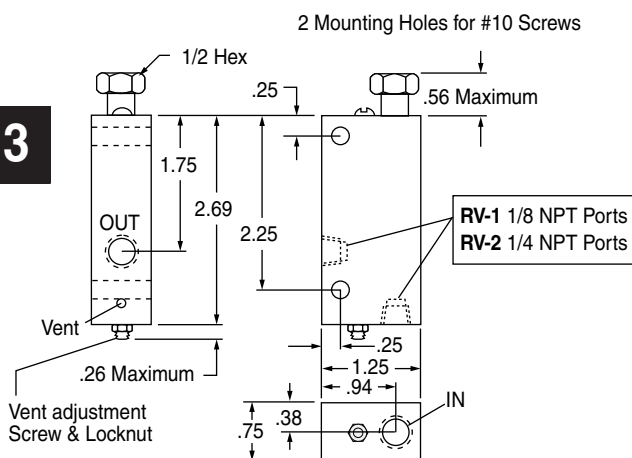

“RV” Valve Function

The “RV”, with its unique poppet type seal, senses the pressure being applied and opens at a pre-adjusted point to provide a pilot signal for circuit control. Because the output force of a cylinder is a direct function of pressure times area, the “RV” provides direct and precision adjustable force sensing.

If the application requires that a predetermined force be applied to an object at a point that may vary in physical dimension (such as riveting, crimping, etc.) the “RV” is the control to use. It assures that the predetermined force (pressure) is applied. If the system pressure should drop below the “RV’s” set point, the valve cannot open. Therefore the cycle will stop and wait for the required pressure rather than produce an unacceptable rivet or crimp. When the required pressure is restored the cycle will continue.

If the application requires that a particular physical point is reached by the cylinder then a position sensor, such as a limit valve, Hall Effect sensor, Reed Switch, limit switch, or other device should be used.

Pressure Sensing (See circuit on page 13.4) Accurately senses pressure (force) and provides a control signal to retract cylinder.

Applications: Riveting, crimping, marking, staking, molding and more.

Sequencing (See circuit on page 13.4) The pressure rise in a cylinder indicates that it is applying the force intended. When the pressure preset into the “RV” is reached, it produces a signal for the control circuit to initiate the next function, thus the next sequence.

Applications: Step by step extension and retraction of multiple cylinders.

Time delay or Function delay (See circuit on page 13.4) Coupled with a flow control & volume chamber, the “RV” provides time or function delay.

Applications: Heat sealing, gluing, compacting, time between functions, load or unload time, and many others.

Please note the following:

- This valve is intended for control circuit signals only and **CANNOT** operate a cylinder directly.
- For most consistent accuracy, the “RV” set-point should be at 90% to 95% of incoming system pressure.
- For accurate circuit setup, pressure gages should be installed to monitor incoming circuit pressure and indicate “sensed” pressure. See circuits on page 13.4.

Symbol

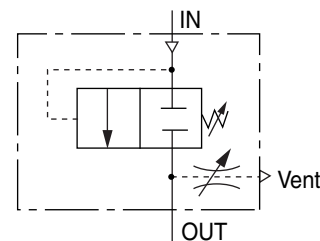

The basic “RV” valve function is two way normally closed. When the input is removed the spring automatically closes the valve, trapping downstream or output pressure. A vent is incorporated in the valve to relieve this trapped signal. The vent is adjustable so that it can be set for various pilot volumes and cycle times. Basic procedure for setting adjustment is to close the vent (turn adjustment screw clockwise), then open 1/4 to 1/2 turn. Fine tuning can then be made from that point.

Sequencing Circuit

1. Start signal to **V1**
2. **C1** - extends to load
3. Load pressure from **C1** to **V2**
4. Constant signal from **V2** to **V3**
5. Pulse signal from **V3** to **V4**
6. **C2** extends to load
7. Load pressure from **C2** to **V5**
8. Signal from **V5** to **V4**
9. **C2** retracts to **V6**
10. Constant signal from **V6** to **V7**
11. Pulse signal from **V7** to **V1**
12. **C1** retracts

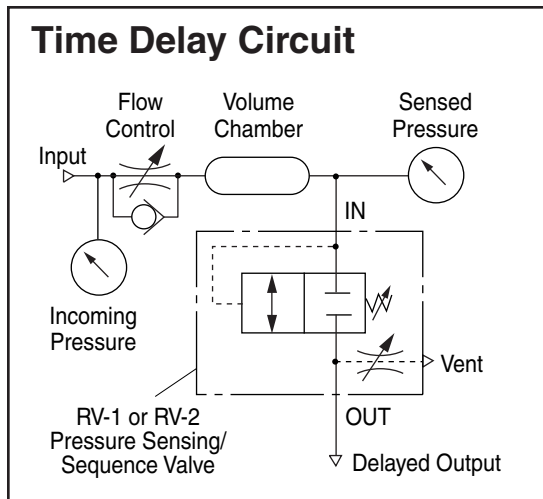
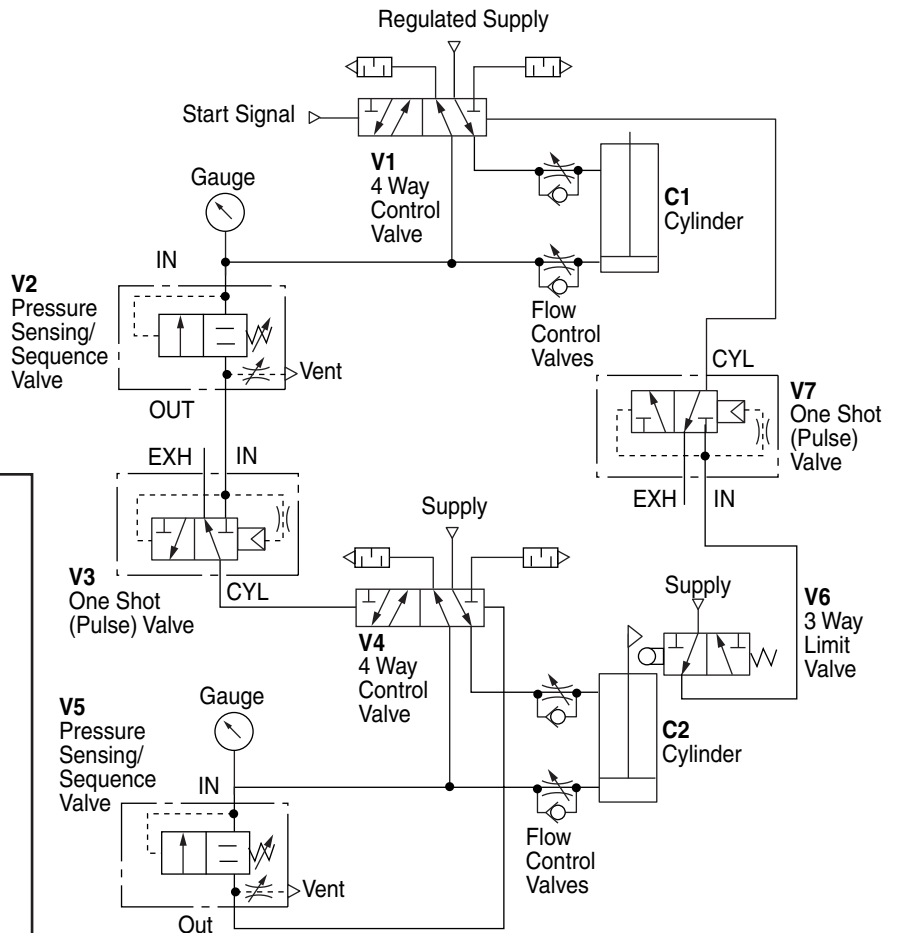

Pressure Sensing Circuit

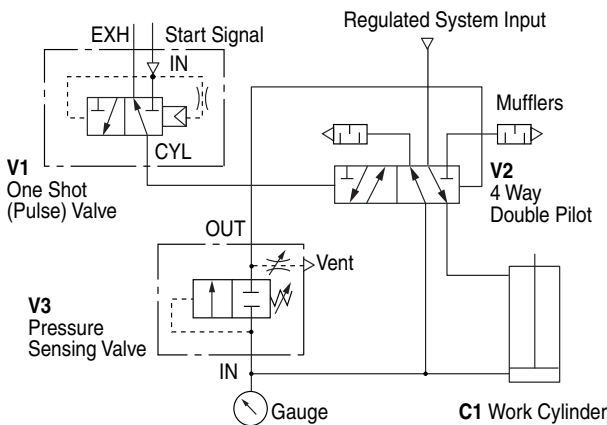

1. Start signal can be maintained or momentary
2. Pulse signal from **V1** to **V2**
3. **C1** extends
4. Load pressure from **C1** to **V3**
5. Signal from **V3** to **V2**
6. **C1** retracts

“RV” Valve Function

As the cylinders in any circuit move, there is a natural pressure drop or differential between the incoming system supply and the cylinder where the “RV” is sensing the pressure. When the cylinder meets its load it slows or stops. Air flow then becomes slow or static and the pressure rises to the “RV” setting. An output signal is then produced by the “RV”. This pressure change (differential) between the dynamic or moving pressure and the static or stopped pressure is a natural function of the cycle and is ESSENTIAL for proper “RV” function. If the load is a constant high load throughout the stroke, or speed controls are closed down causing a consistent high load, the “RV” may see “set point” pressure before the cylinder has done its final work. This results in a premature signal. Therefore, it is highly recommended that a gage be mounted in the “RV” line (as indicated in the circuit) so that the differential or lack thereof can be seen as well as the actual “set point” of the “RV” for cylinder force actuation.

The basic “RV” valve function is two way normally closed. When the input is removed the spring automatically closes the valve, trapping downstream or output pressure. A vent is incorporated in the valve to relieve this trapped signal. That vent is adjustable so that it can be set for various pilot volumes and cycle times. Basic procedure for setting the adjustment is to close the vent (turn adjustment screw clockwise), then open 1/4 to 1/2 turn. Fine tuning can then be made from that point.

Please note that when applying these products or circuit concepts, all safety features that the equipment may warrant should be included and are the responsibility of the user.



MSV-1 Stem Actuator



MSV-2 Lever Actuator



MSV-2A Roller Actuator

Micro Limit Valves

This is a microsize, poppet type, 3 way, normally closed, limit valve. It is primarily designed for momentary contact work that requires very light actuating forces. Therefore, it does not have a 100% seal on the actuating stem. This means that, while the valve is held actuated (and only then), there is a slight bleed to atmosphere around the stem.

Symbol

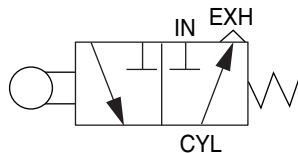

Features

- Machined brass bar stock body
- Brass internal parts
- Buna-N O'Ring seals (-30° to + 250°F)
- Delrin® roller (180° F max.)
- Plated steel lever arm
- Low operating force
 - Lever or roller: 40 psi – 1 oz.
 - 100 psi – 2 oz.
 - Stem: 40 psi – 7 oz.
 - 100 psi – 16 oz.
- Extremely short stroke
 - .005" to .010" movement of stem
 - normally provides sufficient pilot volume.
- Operating pressure 30 to 150 psi
- #10-32 ports
- 3 SCFM free flow at 80 psi

Options

- Viton Seal (-15° to + 400°F); Specify suffix **-V**
- Reverse Lever Assembly; Specify suffix **-R**

Note

The standard assembly of lever, in relation to ports, is shown in the drawings below. A second lever pivot pin hole allows for the lever to be assembled 180° from standard. Specify **Suffix-R, Reverse lever assembly**, if required.

**Model No. MSV-1
Stem Actuator**
Weight 0.8 oz.

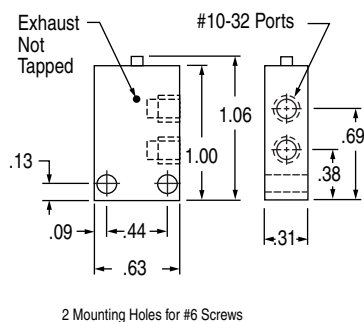

**Model No. MSV-2
Lever Actuator**
Weight 0.8 oz.

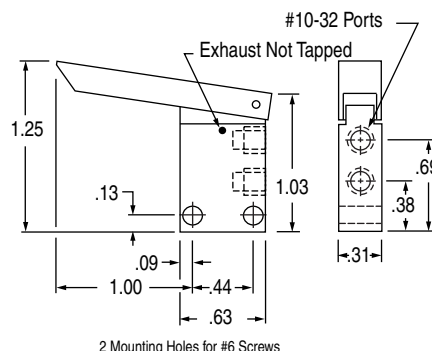

**Model No. MSV-2A
Roller Actuator**
Weight 0.9 oz.

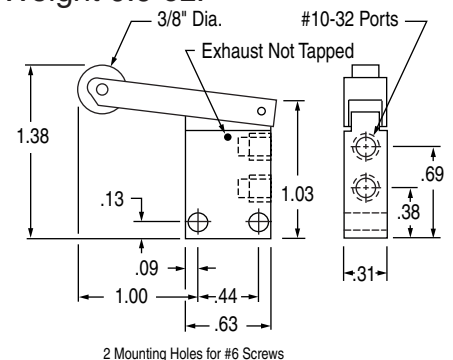

Check Valves

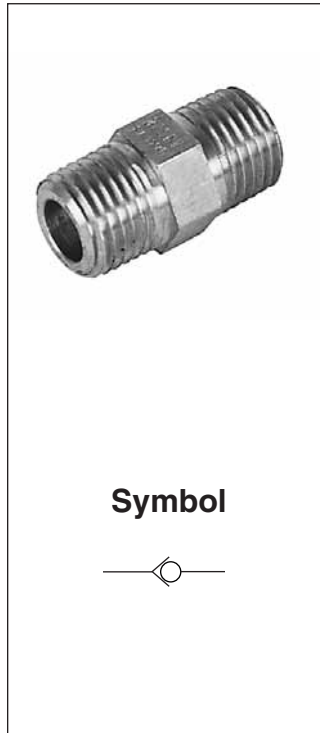

Features

- Machined brass bar stock
- Brass poppet
- Buna-N O'Ring seals (-30° to +250° F)
- Available with or without spring
- Operating pressure: 150 psi max.

Model No. (Cracking Pressure)
18CV (without spring 0.3 psi Max.)
18CVS (with spring 10 psi Max.)
 Weight 0.5 oz.
 Flow rating Cv = 0.1

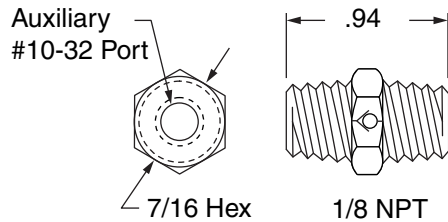

Options

- Viton® O-Ring Seals (-15° to +400° F); Specify Suffix -V

Model No. (Cracking Pressure)
14CV (without spring 0.3 psi Max.)
14CVS (with spring 10 psi Max.)
 Weight 0.8 oz.
 Flow rating Cv = 0.4

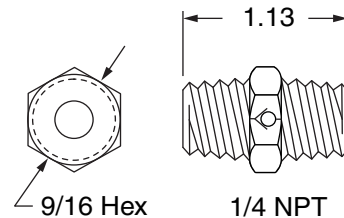

Shuttle Valves



Features

- Machined brass bar stock
- Light weight Delrin® poppet
- Operating temperature: (0° to +180° F)
- Buna-N O'Ring seals
- Operating pressure: 10 to 150 psi

Model No. 10 SV
 Weight 0.4 oz.
 Flow rating Cv approx. 0.06

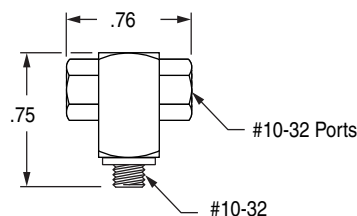

Options

- Viton® O-Ring Seals (for media compatibility); Specify Suffix -V

Model No. 18 SV
 Weight 1.4 oz.
 Flow rating Cv approx. 0.34

