

FKHW Series

NEW PRODUCT

Features

1. Magnetic piston is standard feature.
2. Adding optional sensors enable "open" and "close" position sensing.
3. Rack and pinion design synchronizes finger motion.
4. Fingers are heat treated for durability.
5. All bearings are sealed for longer operational life.
6. Compact design make grippers ideal for handling various sized workpieces in confined areas.
7. Gripper body is hardcoated aluminum ensuring abrasion and corrosion resistance.
8. No extra lubrication required.



Specifications 25mm Bore – Double Acting

Media	Compressed air
Operating pressure	0.15 MPa (22 psi) to 0.7 MPa (101 psi)
Ambient & media temperature	-10°C(14°F) ~ +60°C(140°F)
Lubrication	None required or use ISO VG32
Repeatability	±0.2 mm
Max. operating frequency	60 c.p.m.
Effective gripping force	5.1 lbf at 87 psi & L = 40mm grip point

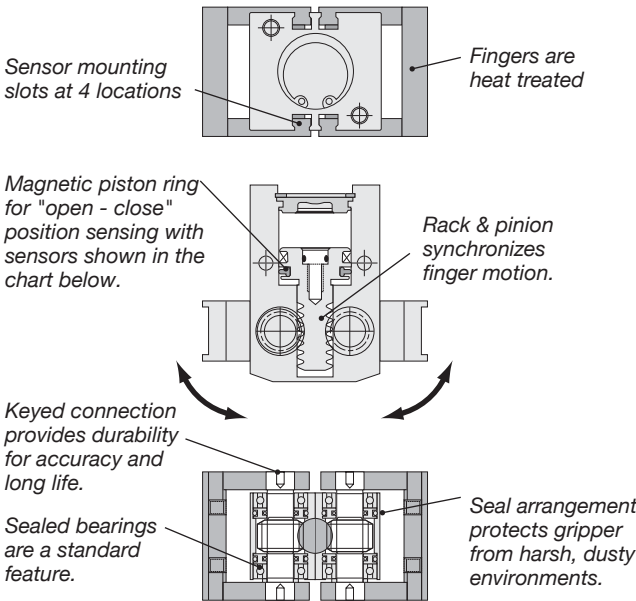

How to Order

FKHW	25	Please order sensors and female cordsets separately. See selection guide below.	
Series	Bore	Action	Price
	ø25	Double acting	\$356.45

Position Sensors

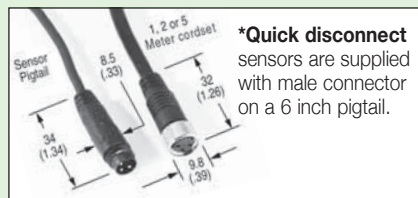
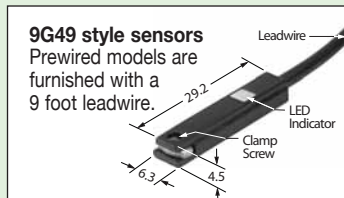

*Note: All quick disconnect style sensors are supplied with 6 inch pigtail with male connector.

Female Cord Sets	Part No.	Price
1 Meter	CFC-1M	\$15.05
2 Meters	CFC-2M	16.85
5 Meters	CFC-5M	21.30

6.3 mm wide	9G49 Sensor List Prices & Selection Guide		Prewired 9 ft. Leadwire Part No.	Price	Quick Disconnect* Part No.	Price
	Sensor Type	Electrical Characteristics				
	Reed (LED)	5-120 VDC/VAC, 0.03 Amp max, 0.005 AMP min, 4 Watt max., 2.0 voltage drop	9G49-000-002	\$14.70	9G49-000-302	\$17.35
	Electronic (LED)	Sourcing PNP 5-28 VDC, 0.20 Amp max current, 0.5 voltage drop	9G49-000-031	28.80	9G49-000-331	31.45
	Electronic (LED)	Sinking NPN 5-28 VDC, 0.20 Amp max current, 0.5 voltage drop	9G49-000-032	28.80	9G49-000-332	31.45

