

# FKHL Series Wide Parallel Grippers

**Prices effective  
September 1, 2011**



## Features

1. Grippers have compact design and are ideal for various-sized workpieces.
2. Dual piston mechanism delivers high grip force.
3. Fingers are synchronized by a rack & pinion mechanism.
4. Oil impregnated sleeve bearings encased in steel are used for all shafts.
5. Rod scraper for dust protection is built in.
6. Magnetic piston is standard feature.
7. Adding optional sensors enables "open" and "close" position sensing.
8. Gripper body is hard coated aluminum ensuring abrasion and corrosion resistance.
9. No extra lubrication required.

## How to Order

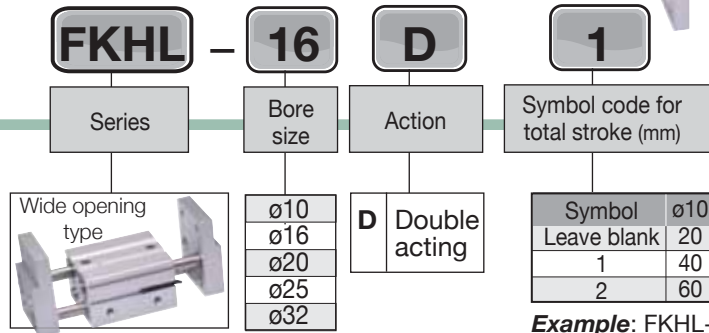

**Example:** FKHL-16D1 is 16mm bore double acting 60mm total stroke.

## Price list

Model	Price	Model	Price
FKHL-10D	\$ 171.50	FKHL-25D	\$ 253.80
FKHL-10D1	187.25	FKHL-25D1	285.30
FKHL-10D2	189.00	FKHL-25D2	297.50
FKHL-16D	185.55	FKHL-32D	346.50
FKHL-16D1	201.30	FKHL-32D1	383.25
FKHL-16D2	210.00	FKHL-32D2	421.80
FKHL-20D	222.30		
FKHL-20D1	246.75		
FKHL-20D2	259.05		

## Specifications

Bore size (mm)	ø10	ø16	ø20	ø25	ø32
Media	Compressed air				
Action	Double acting				
Min. operating pressure	25 psi	15 psi			
Max. operating pressure	0.6 MPa (87 psi)				
Ambient & media temperature	-10°C(14°F) ~ +60°C(140°F)				
Lubrication	None required or use ISO VG32				
Repeatability	±0.2 mm				
*Effective gripping force (lbf)	3.1	10.1	16.6	29.4	51.2

## Position Sensors

\*Note: Shortest stroke model, 72 psi and gripping point for ø10, ø16, ø20, ø25 = 40mm; ø32 = 80mm

**9G49 style sensors**  
Prewired models are furnished with a 9 foot leadwire.

**\*Quick disconnect sensors** are supplied with male connector on a 6 inch pigtail.

Female Cord Sets	Part No.	Price
1 Meter	CFC-1M	\$15.05
2 Meters	CFC-2M	16.85
5 Meters	CFC-5M	21.30

9G49 Sensor List Prices & Selection Guide				
6.3 mm wide	Sensor Type	Electrical Characteristics		
	Reed (LED)	5-120 VDC/VAC, 0.03 Amp max, 0.005 AMP min, 4 Watt max., 2.0 voltage drop	9G49-000-002 .....\$14.70	9G49-000-302 .....\$17.35
	Electronic (LED)	Sourcing PNP 5-28 VDC, 0.20 Amp max current, 0.5 voltage drop	9G49-000-031 .....28.80	9G49-000-331 .....31.45
	Electronic (LED)	Sinking NPN 5-28 VDC, 0.20 Amp max current, 0.5 voltage drop	9G49-000-032 .....28.80	9G49-000-332 .....31.45
		Prewired 9 ft. Leadwire Part No.	Quick Disconnect* Part No.	
		Price	Price	

# FKHL Series

## Wide Parallel Grippers

### Gripping Point

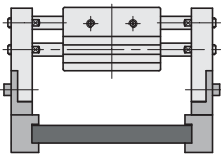

**R = Holding position (mm)**  
 0.2 MPa = 29 psi  
 0.3 MPa = 43 psi  
 0.4 MPa = 58 psi  
 0.5 MPa = 72 psi  
 0.6 MPa = 87 psi

- Make sure that the workpiece gripping point distance is within the range of the gripping force lines indicated by each pressure in the effective gripping force graph.
- If it is used in an area in which the workpiece gripping point distance is longer than the length indicated in the diagram, the load that will be applied to the fingers or the guide will become excessively unbalanced. As a result, the fingers could become loosened and adversely affect the service life of the unit.

### Effective Gripping Force

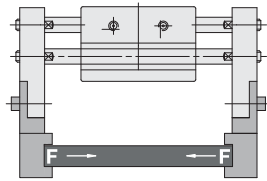

The holding force shown in the tables represents the holding force of one finger when all fingers and attachments are in contact with the workpiece, F = one finger thrust.

### Model/Stroke

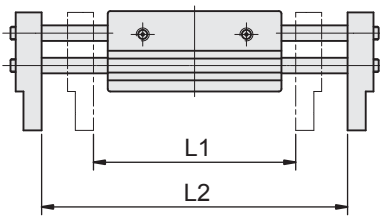

Model	Bore size (mm)	Max cycle speed (CPM)	Open/close stroke L2-L1(mm)	Width when closed (mm) L1	Width when open (mm) L2	Weight g (lb)
FKHL-10D	10	60	20	56	76	280 (0.61)
FKHL-10D1			40	78	118	345 (0.76)
FKHL-10D2		60	96	156	425 (0.94)	
FKHL-16D	16	60	30	68	98	585 (1.29)
FKHL-16D1			60	110	170	795 (1.75)
FKHL-16D2		80	130	210	935 (2.06)	
FKHL-20D	20	60	40	82	122	1025 (2.26)
FKHL-20D1			80	142	222	1495 (3.30)
FKHL-20D2		100	162	262	1690 (3.73)	
FKHL-25D	25	60	50	100	150	1690 (3.73)
FKHL-25D1			100	182	282	2560 (5.64)
FKHL-25D2		120	200	320	2775 (6.12)	
FKHL-32D	32	30	70	150	220	2905 (6.41)
FKHL-32D1			120	198	318	3820 (8.42)
FKHL-32D2		20	160	242	402	4655 (10.3)

Note: The open and close time spans represent the value when the exterior of the workpiece is being held.

Specifications and prices subject to change without notice or incurring obligation.

### Sizing Charts

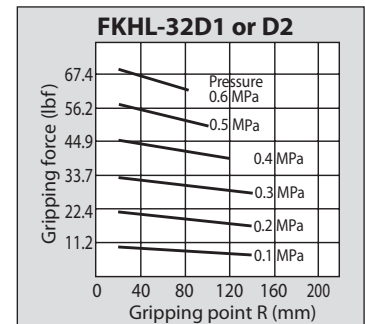
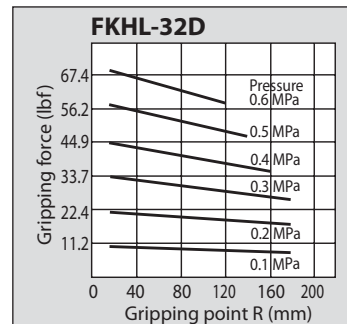
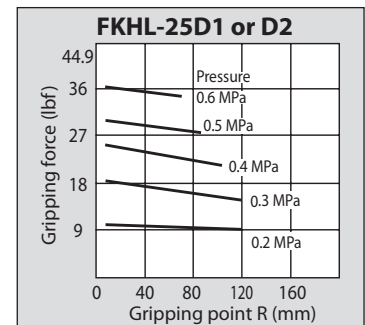
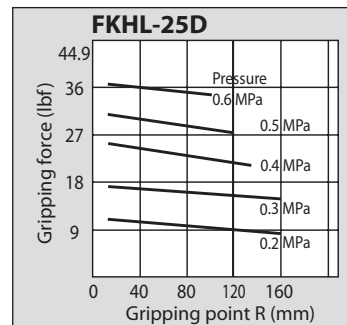
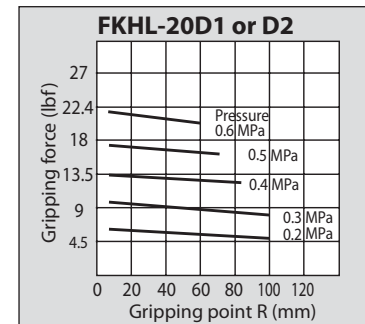
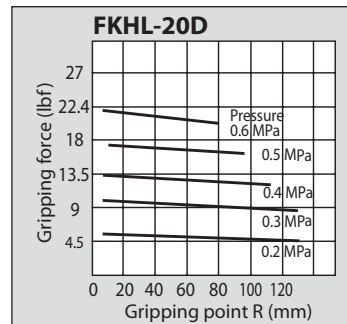
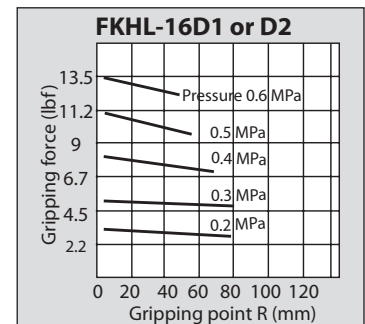
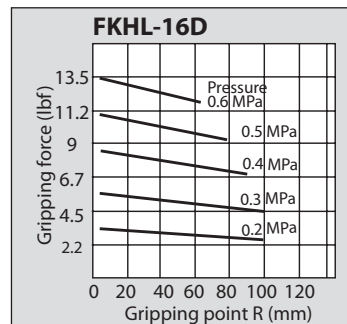
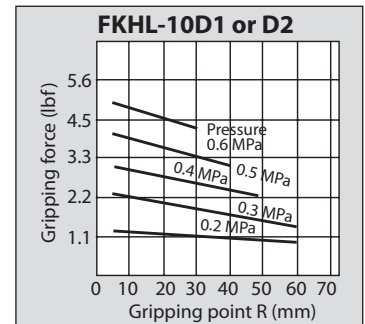
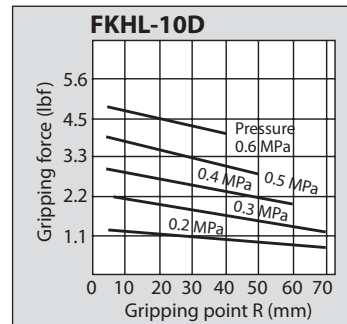

# FKHL Series

## Wide Parallel Grippers – Dimensions

### FKHL10

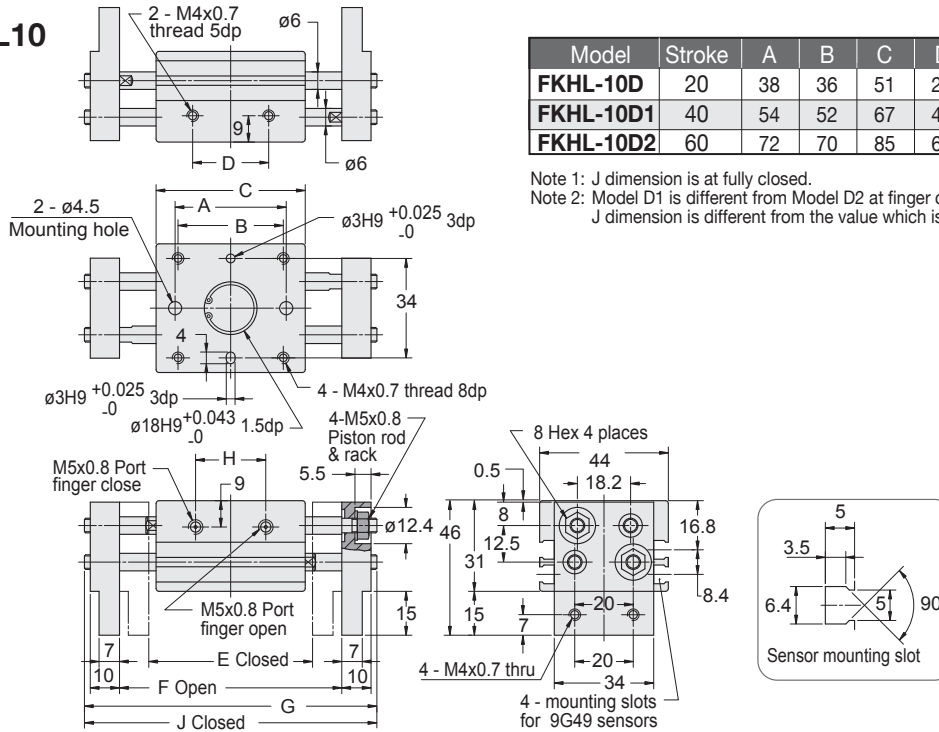

Model	Stroke	A	B	C	D	E	F	G	H	J
FKHL-10D	20	38	36	51	26	56	76	100	24	80
FKHL-10D1	40	54	52	67	42	78	118	142	39	108
FKHL-10D2	60	72	70	85	60	96	156	180	57	146

Note 1: J dimension is at fully closed.  
Note 2: Model D1 is different from Model D2 at finger closed because shaft projects from finger end. J dimension is different from the value which is subtracted stroke from G dimension.

### FKHL16

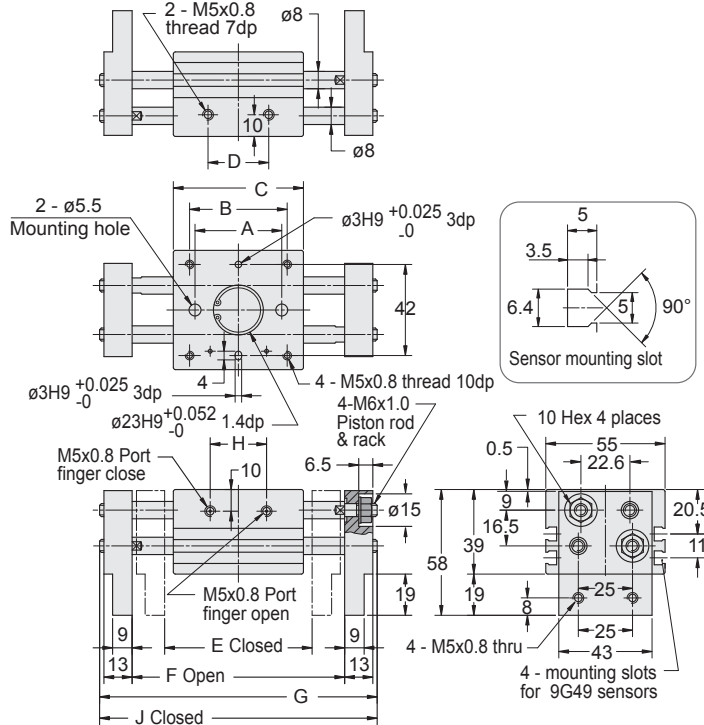

Model	Stroke	A	B	C	D	E	F	G	H	J
FKHL-16D	30	40	45	60	28	68	98	128	26	98
FKHL-16D1	60	70	75	90	58	110	170	200	50	152
FKHL-16D2	80	90	95	110	78	130	210	240	70	192

Note 1: J dimension is at fully closed.  
Note 2: Model D1 is different from Model D2 at finger closed because shaft projects from finger end. J dimension is different from the value which is subtracted stroke from G dimension.

### FKHL20

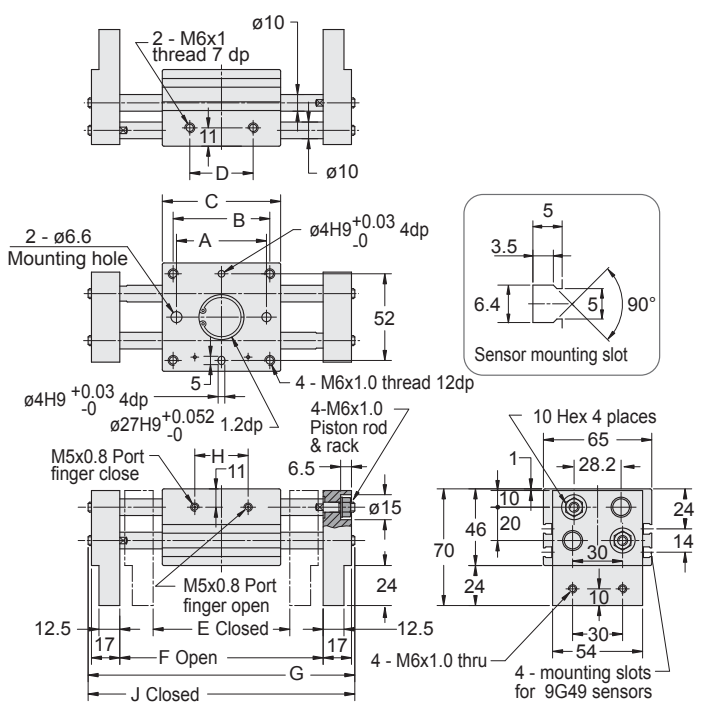

Model	Stroke	A	B	C	D	E	F	G	H	J
FKHL-20D	40	54	58	71	38	82	122	160	32	120
FKHL-20D1	80	96	100	113	80	142	222	260	68	195
FKHL-20D2	100	116	120	133	100	162	262	300	88	235

Note 1: J dimension is at fully closed.  
Note 2: Model D1 is different from Model D2 at finger closed because shaft projects from finger end. J dimension is different from the value which is subtracted stroke from G dimension.

**FKHL25**

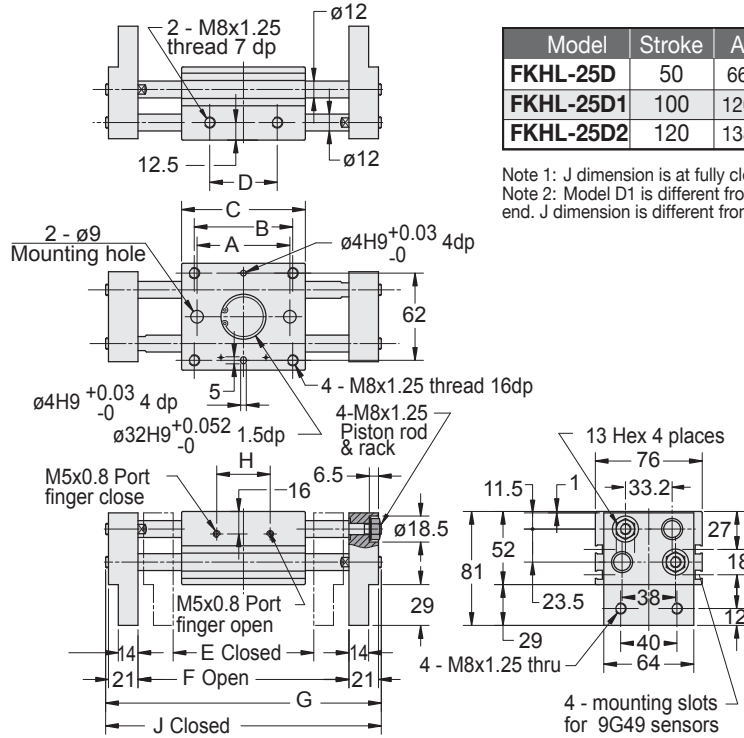

Model	Stroke	A	B	C	D	E	F	G	H	J
<b>FKHL-25D</b>	50	66	70	88	48	100	150	196	38	146
<b>FKHL-25D1</b>	100	120	124	142	102	182	282	328	86	244
<b>FKHL-25D2</b>	120	138	142	160	120	200	320	366	104	282

Note 1: J dimension is at fully closed.  
 Note 2: Model D1 is different from Model D2 at finger closed because shaft projects from finger end. J dimension is different from the value which is subtracted stroke from G dimension.

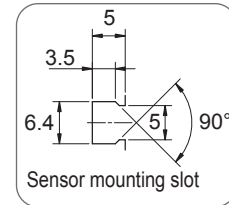

**FKHL32**

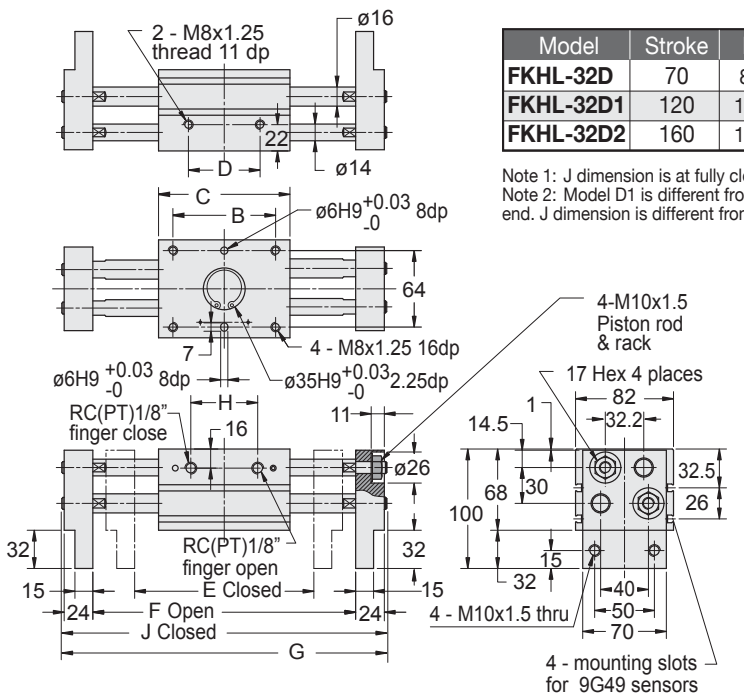

Model	Stroke	B	C	D	E	F	G	H	J
<b>FKHL-32D</b>	70	86	110	60	150	220	272	56	202
<b>FKHL-32D1</b>	120	134	158	108	198	318	370	104	282
<b>FKHL-32D2</b>	160	178	202	152	242	402	454	148	366

Note 1: J dimension is at fully closed.  
 Note 2: Model D1 is different from Model D2 at finger closed because shaft projects from finger end. J dimension is different from the value which is subtracted stroke from G dimension.

